

FLOORING AREAS:

- CARPET TILE 368m²
- KITCHEN VINYL 7m²

NOTE:
AREA m² ARE APPROXIMATES ONLY. ALLOWANCE FOR WASTAGE IS REQUIRED ON TOP.
ALL AREA CALCULATIONS TO BE CONFIRMED ON SITE BY MANUFACTURER PRIOR TO ORDER CONFIRMATION.

WALL LEGEND:

RONDO 92mm QUIET STUD WITH PINK BATTS SILENCER.
2x 13mm GIB STANDARD PLASTERBOARD EACH SIDE.
STOPPED TO L4. SELECTED PAINT FINISH.

NOTE:
POWER POINT AND PHONE POINT LOCATION TO BE CONFIRMED ON SITE BY TENANT PRIOR TO INSTALLATION

SECOND FLOOR PLAN
SCALE: 1:100 @ A2

ISSUED FOR BUILDING CONSENT NOT SUITABLE FOR CONSTRUCTION WITHOUT C.C.C ENDORSEMENT

SECOND FLOOR PARTITION LAYOUT

SCALE : 1:100 @ A2
DATE : 30/03/2015
PROJECT No: 9220

A1.01

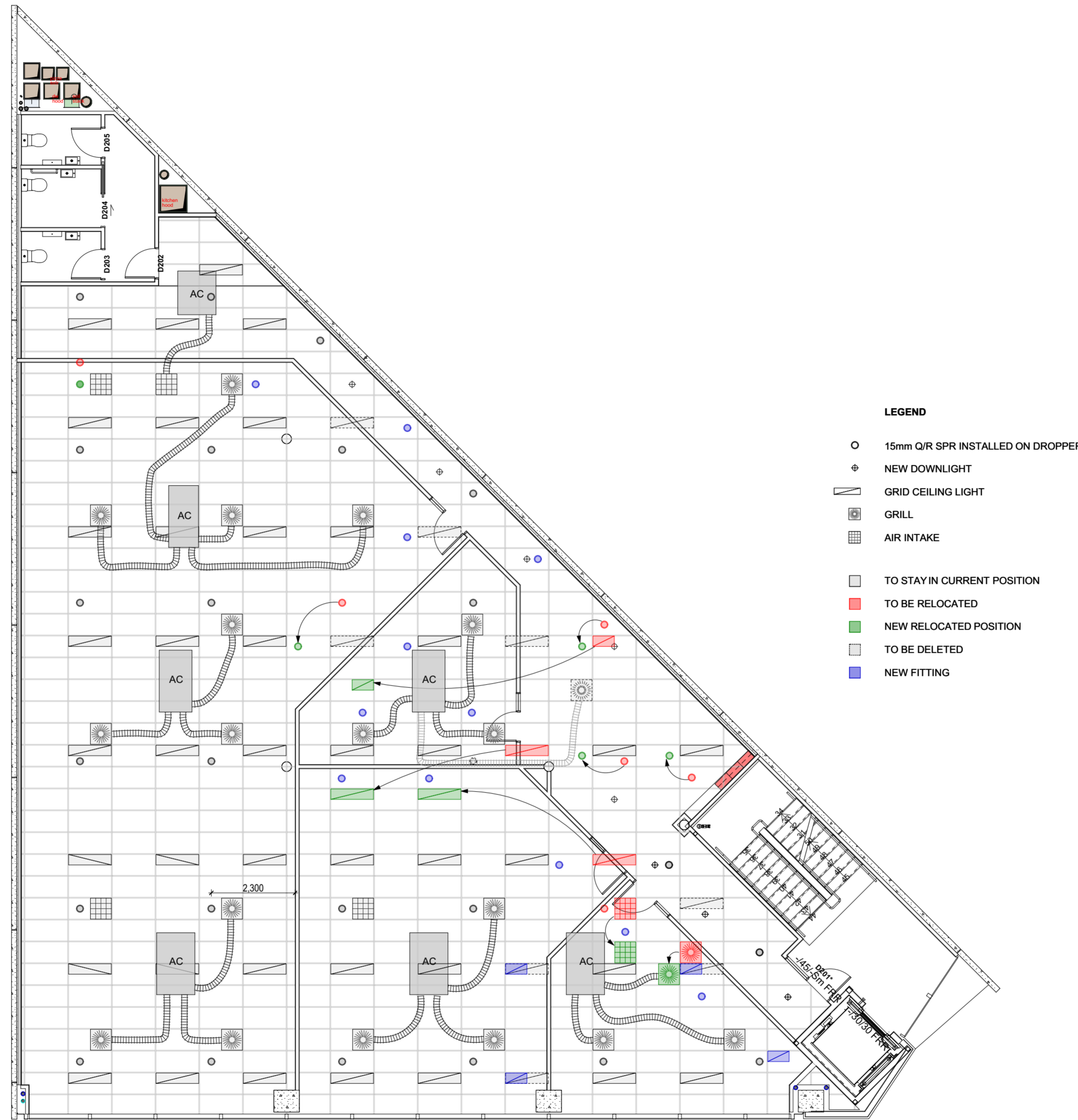

**ISSUED FOR BUILDING
CONSENT NOT SUITABLE
FOR CONSTRUCTION
WITHOUT C.C.C
ENDORSEMENT**

RCP
SCALE : 1:100 @ A2
DATE : 30/03/2015
PROJECT No: 9220

A1.02

MAP ARCHITECTS (2010) Ltd
143 Victoria Street | p: +64 3 962 6530
PO Box 667 | f: +64 3 962 6541
Christchurch | info@maparchitects.co.nz
New Zealand | www.maparchitects.co.nz

DO NOT SCALE DRAWING. CONTRACTOR TO VERIFY ALL DIMENSIONS PRIOR TO COMMENCING WORK

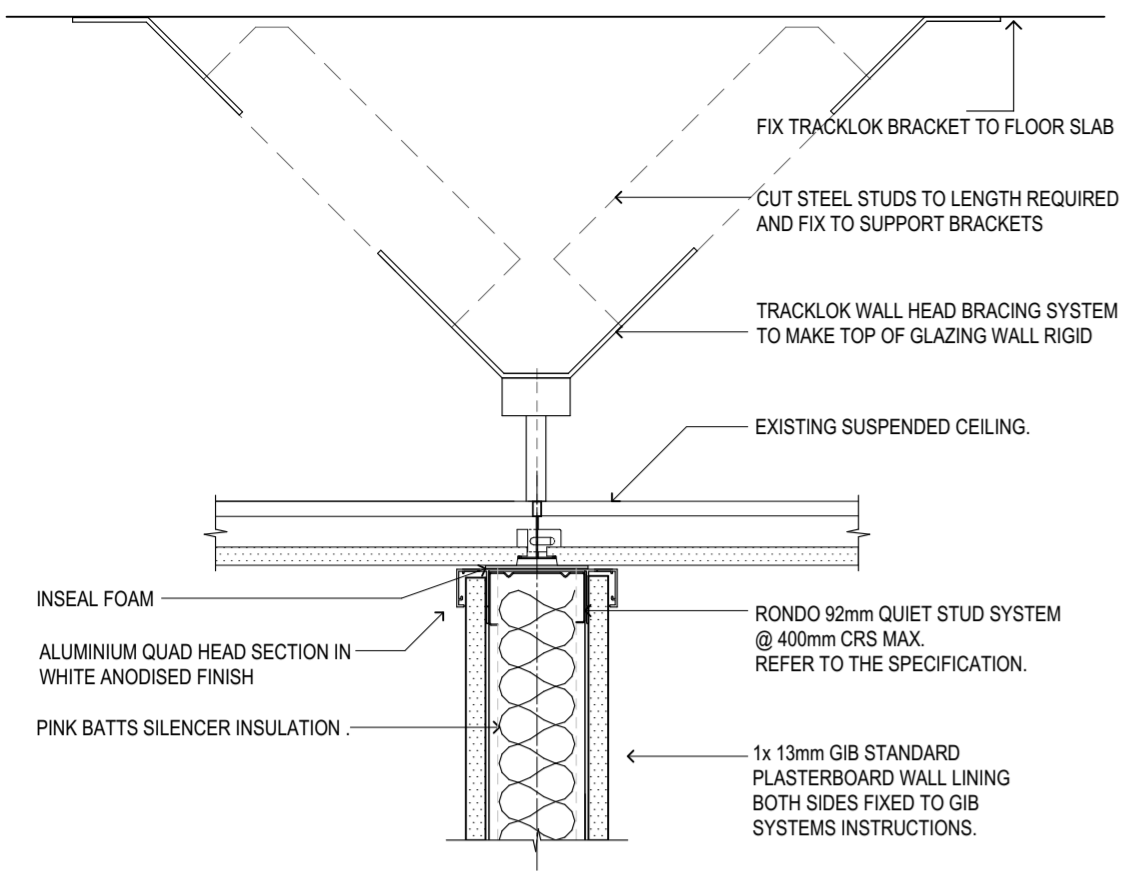

01 PARTITION WALL @ CEILING DETAIL 50STC
SCALE 1:5

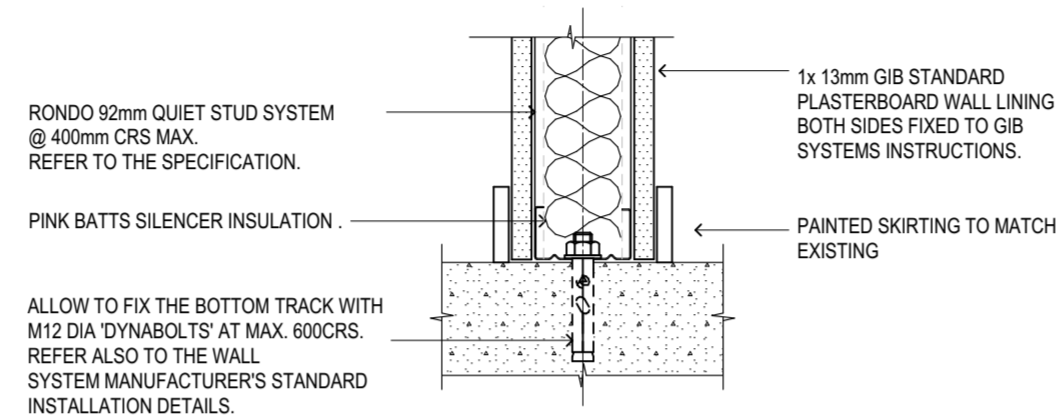

02 TYPICAL PARTITION WALL @ FLOOR DETAIL (PLASTERBOARD)
SCALE 1:5

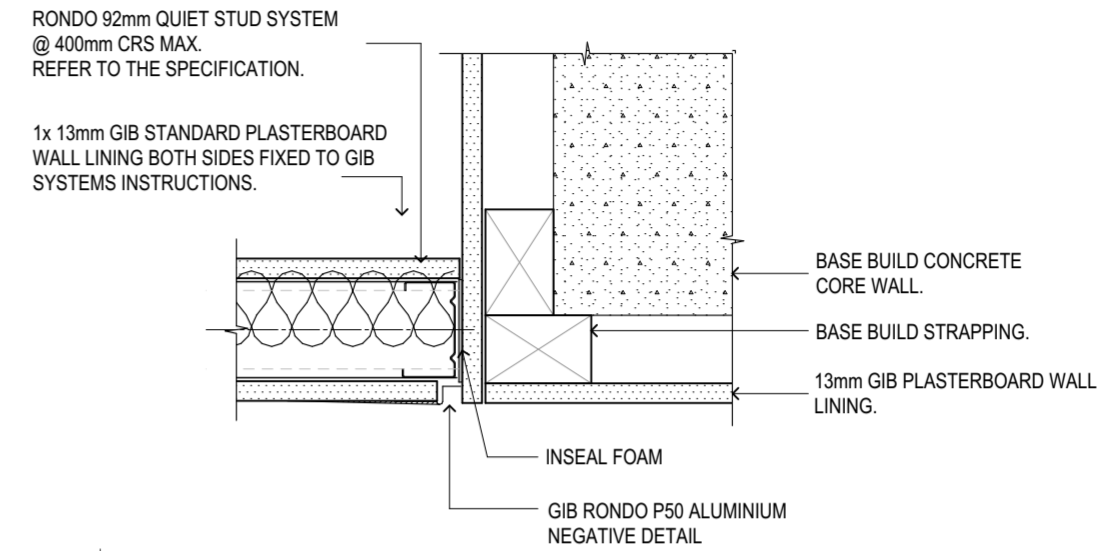

03 TYPICAL WALL/CORE DETAIL (PLAN VIEW)
SCALE 1:5

NOTE:
ALLOW TO SECURE TOP OF WALLS AND DOORS BACK TO SLAB STRUCTURE ABOVE CEILING AND NOT TO SUSPENDED CEILING. POTTERS 'TRACKLOK' OR SIMILAR APPROVED SYSTEM.

NOTE:
REFER TO FORMANS PARTITIONS DETAILS

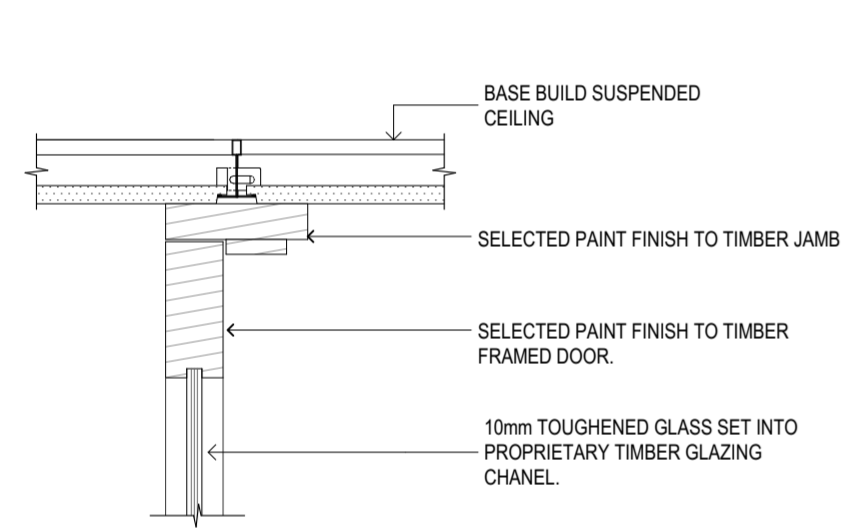

04 TYPICAL DOOR HEAD DETAIL
SCALE 1:5

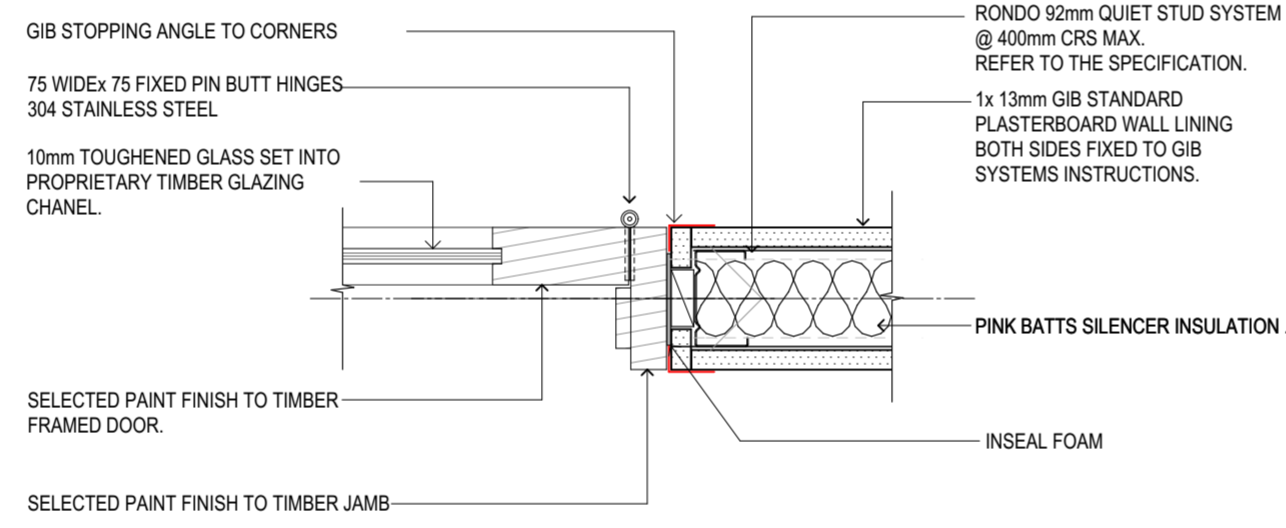

05 TYPICAL DOOR JAMB DETAIL
SCALE 1:5

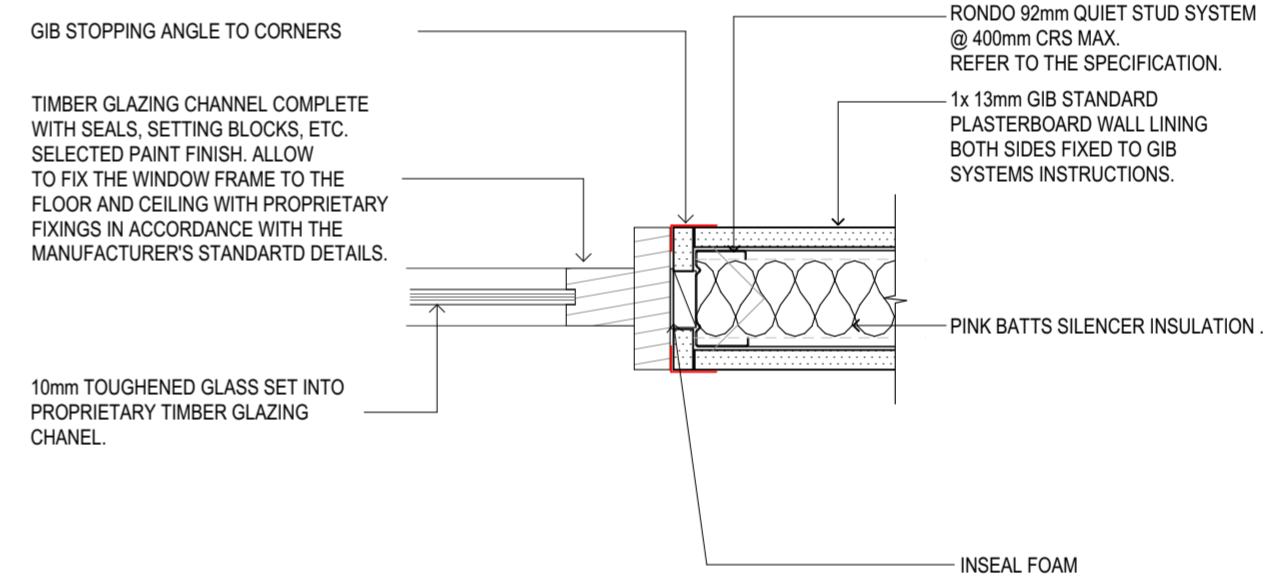

06 TYPICAL GLAZING JAMB DETAIL
SCALE 1:5

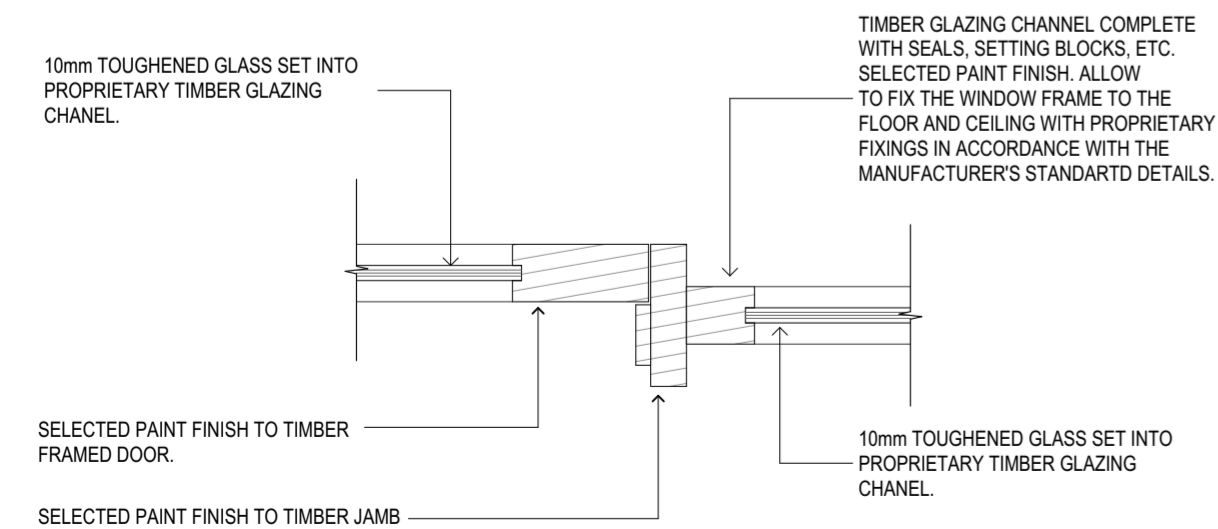

07 TYPICAL GLAZING JAMB DETAIL
SCALE 1:5

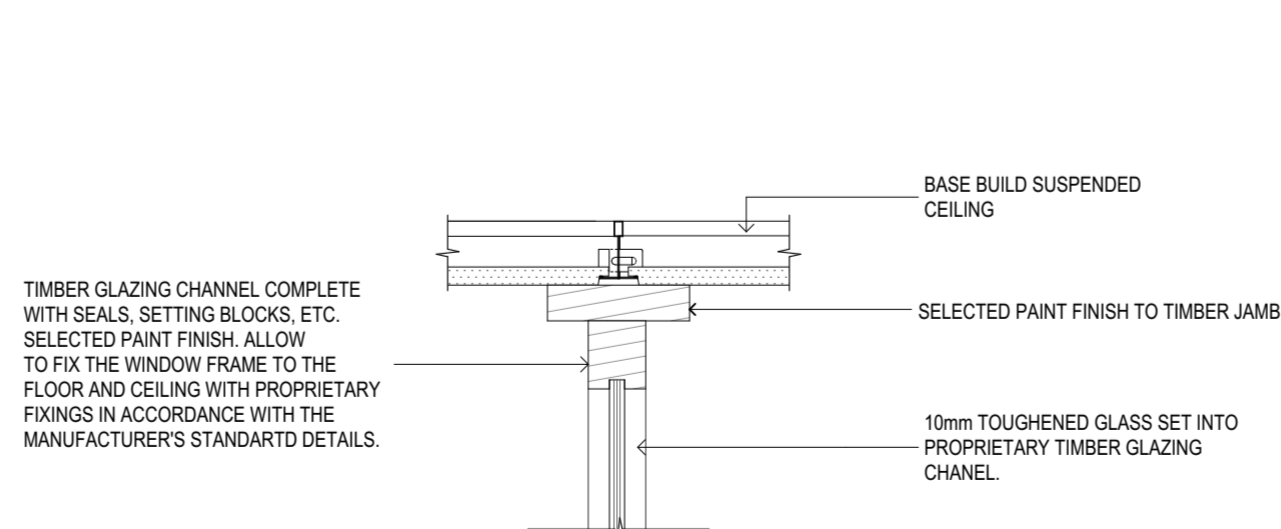

08 TYPICAL GLAZING @ CEILING DETAIL
SCALE 1:5

ISSUED FOR BUILDING CONSENT NOT SUITABLE FOR CONSTRUCTION WITHOUT C.C.C ENDORSEMENT

DETAILS

SCALE : 1:5 @ A2
DATE : 30/03/2015
PROJECT No: 9220

A1.03

MAP ARCHITECTS (2010) Ltd

143 Victoria Street
PO Box 667
Christchurch
New Zealand
p: +64 3 962 6530
f: +64 3 962 6541
info@maparchitects.co.nz
www.maparchitects.co.nz

DO NOT SCALE DRAWING. CONTRACTOR TO VERIFY ALL DIMENSIONS PRIOR TO COMMENCING WORK